

HiKEY SCH

1. Catalog
2. Power Tree
3. 12V IN
4. USB/Hub
5. PMU-1
6. PMU-2
7. PMU Codec
8. SOC-1 System
9. SOC-2-GPIO
10. SOC-3-Media
11. SOC-4-MEM
12. SOC-5-RF
13. SOC-6-POWER
14. SOC-7-GND
15. LRDDR3
16. EMMC
17. HDMI
18. IO_CONN
19. WIFI

The type and specification of the components refer to the BOM

				NA	
				ECA NO	DATE
DESIGNED			Hi6220HiKEY		
REVIEWED					
		VER	PART_NUMBER	SHEET	OF
		A		HUAWEI TECH CO.,LTD.	

Power Tree

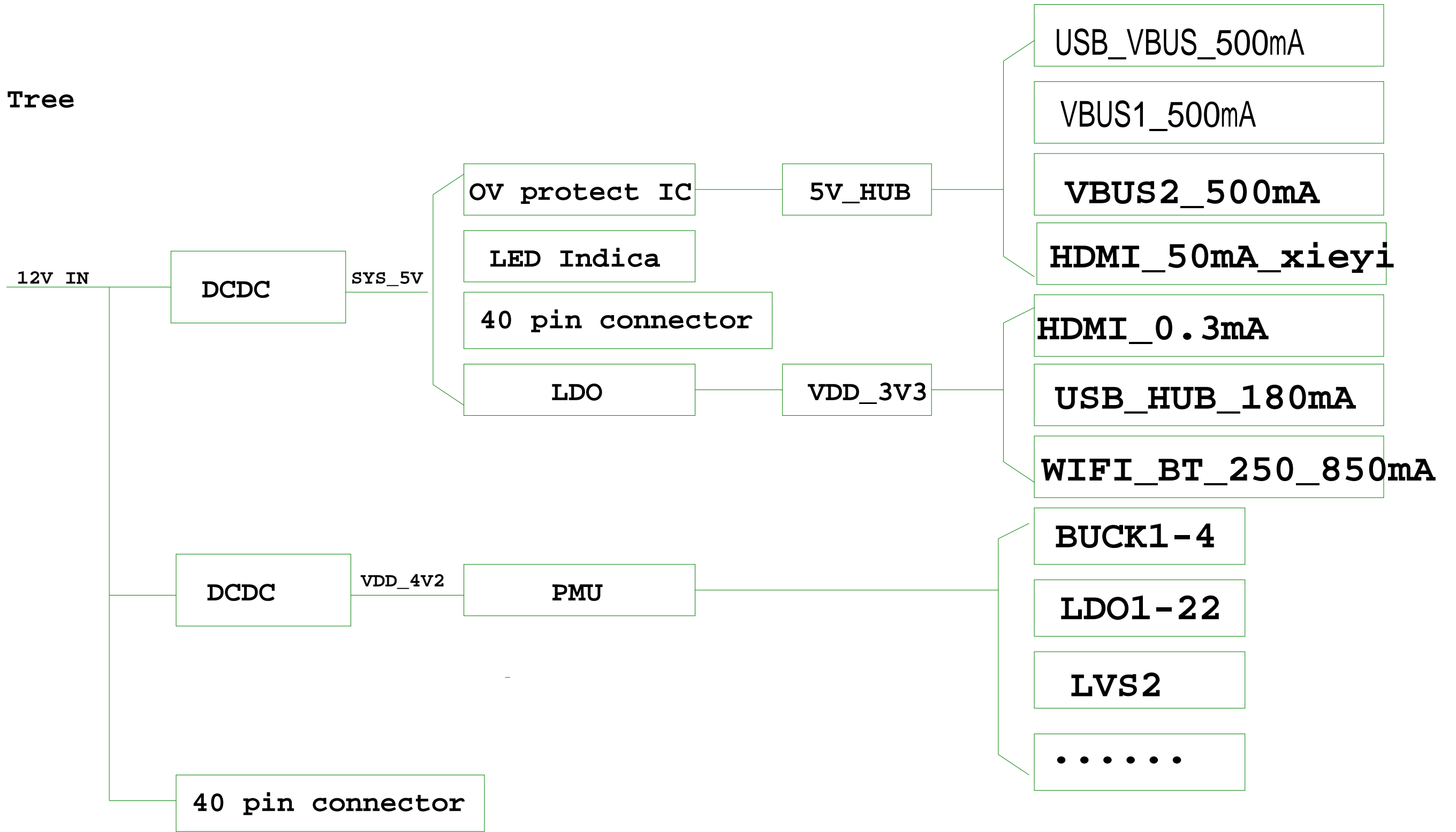

The type and specification of the components refer to the BOM

				NA	
				ECA NO	DATE
DESIGNED			Hi6220HiKEY		
REVIEWED					
		VER	PART_NUMBER	SHEET	OF
		A		HUAWEI TECH CO.,LTD.	

DC 8-18V Input

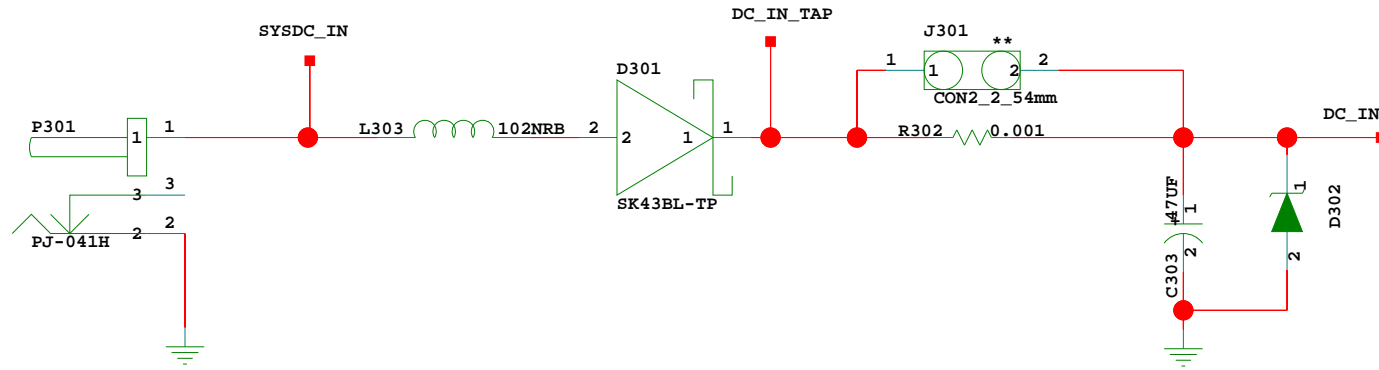

5VDC to 3V3DC

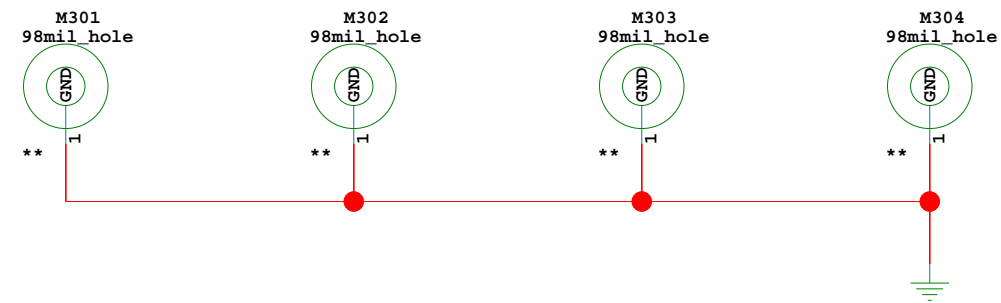
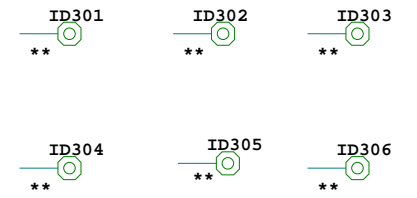
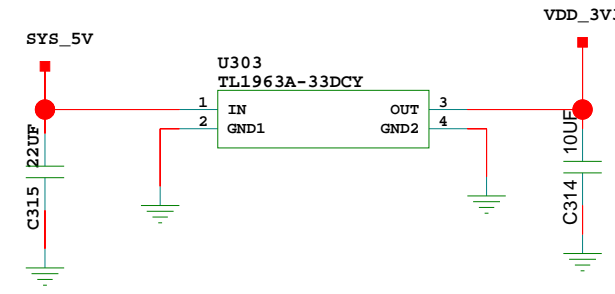

DC_IN 12V0 To 5V 2.6A

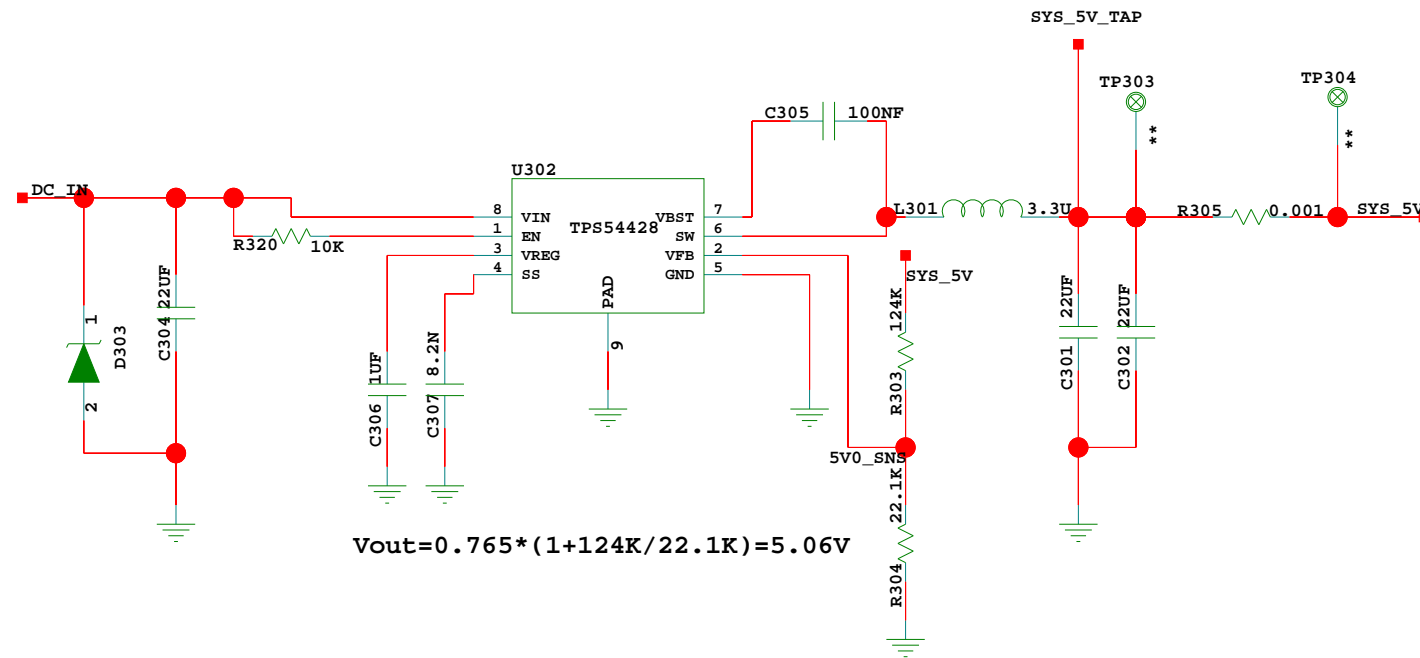

$$V_{out} = 0.765 * (1 + 124K / 22.1K) = 5.06V$$

DC_IN 12V0 To 4.2V 2.6A

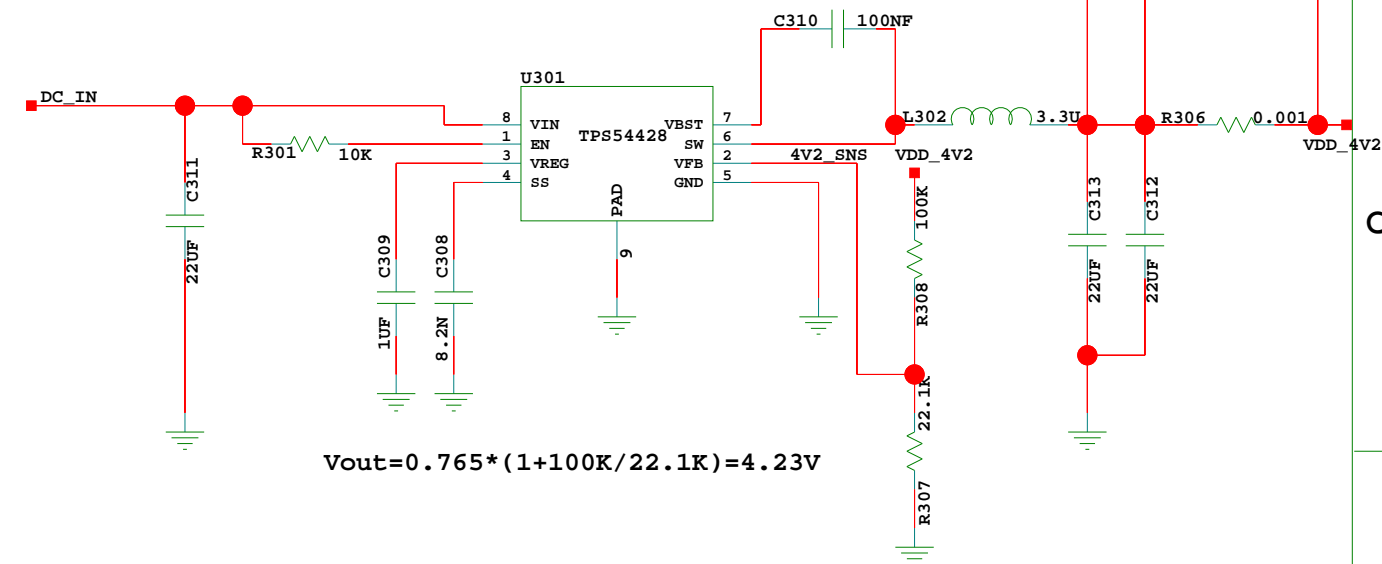

$$V_{out} = 0.765 * (1 + 100K / 22.1K) = 4.23V$$

The type and specification of the components refer to the BOM

DESIGNED	Hi6220HiKEY		NA	DATE
REVIEWED	VER	PART_NUMBER	SHEET	OF
	A		HUAWEI TECH CO.,LTD.	

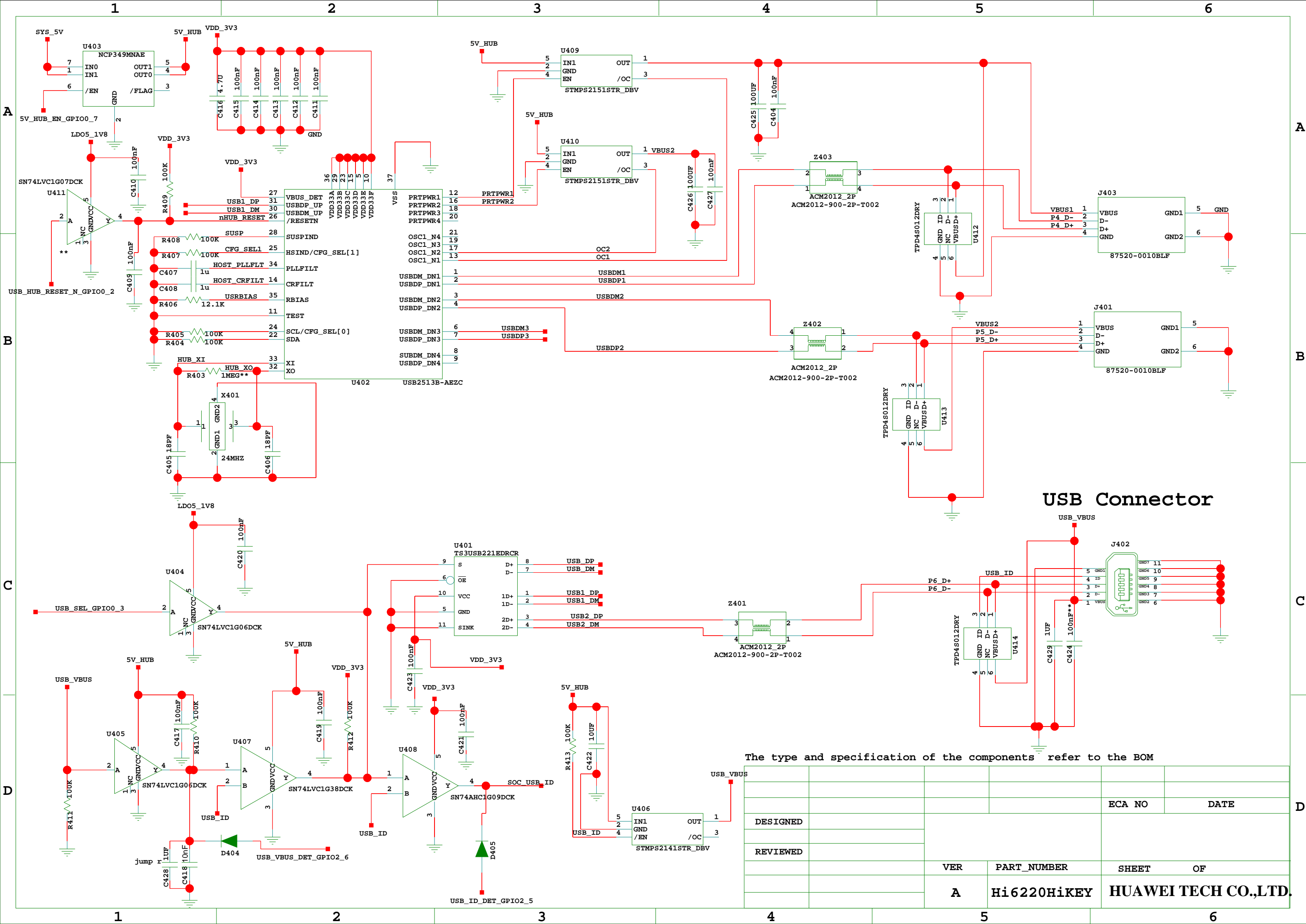

USB Connector

The type and specification of the components refer to the BOM

		ECA NO	DATE
DESIGNED			
REVIEWED			
VER	PART_NUMBER	SHEET	OF
A	Hi6220HiKEY	HUAWEI TECH CO.,LTD.	

PMU-2

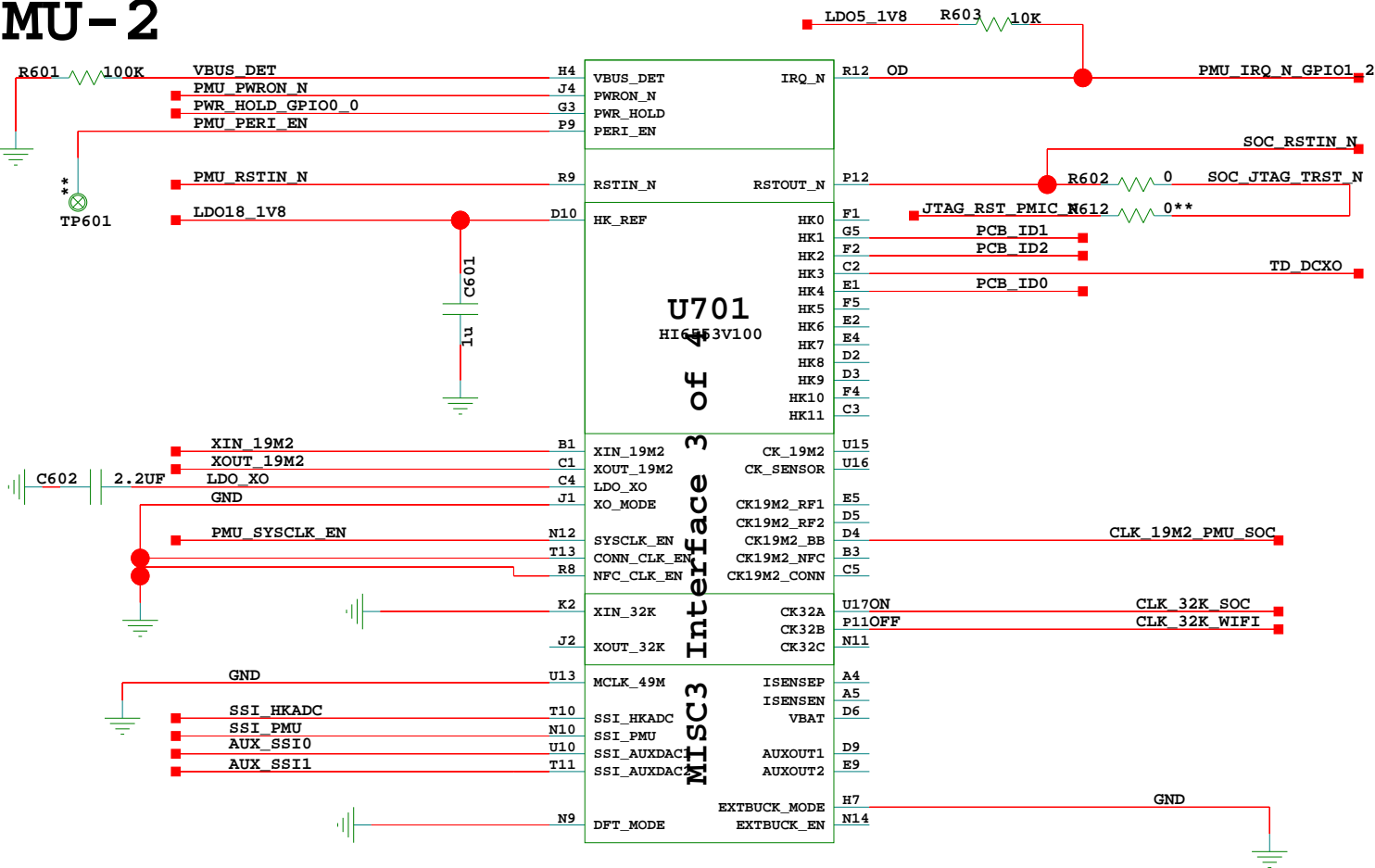

Board ID

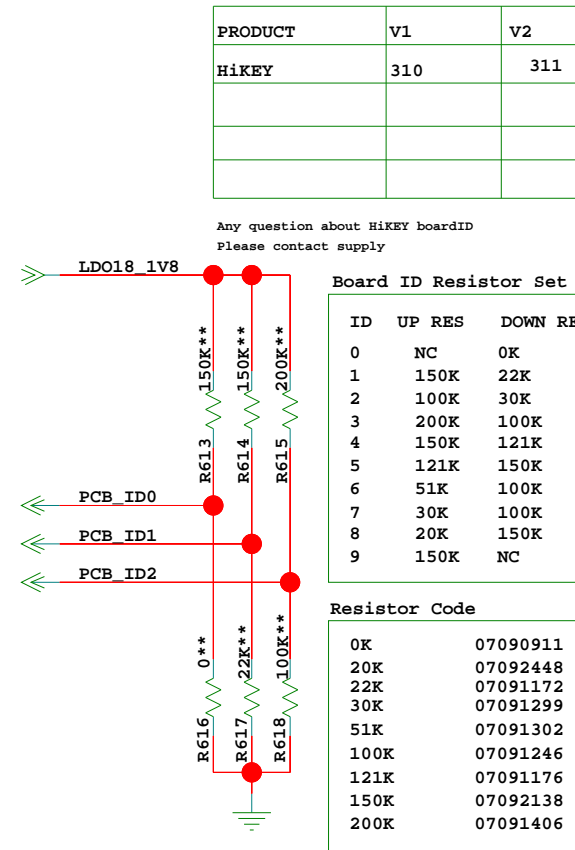

19.2M CLK_{DCXO}

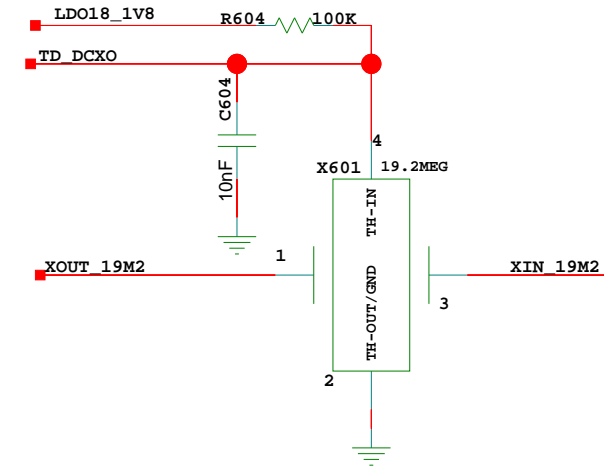

RESET & Power Button KEY

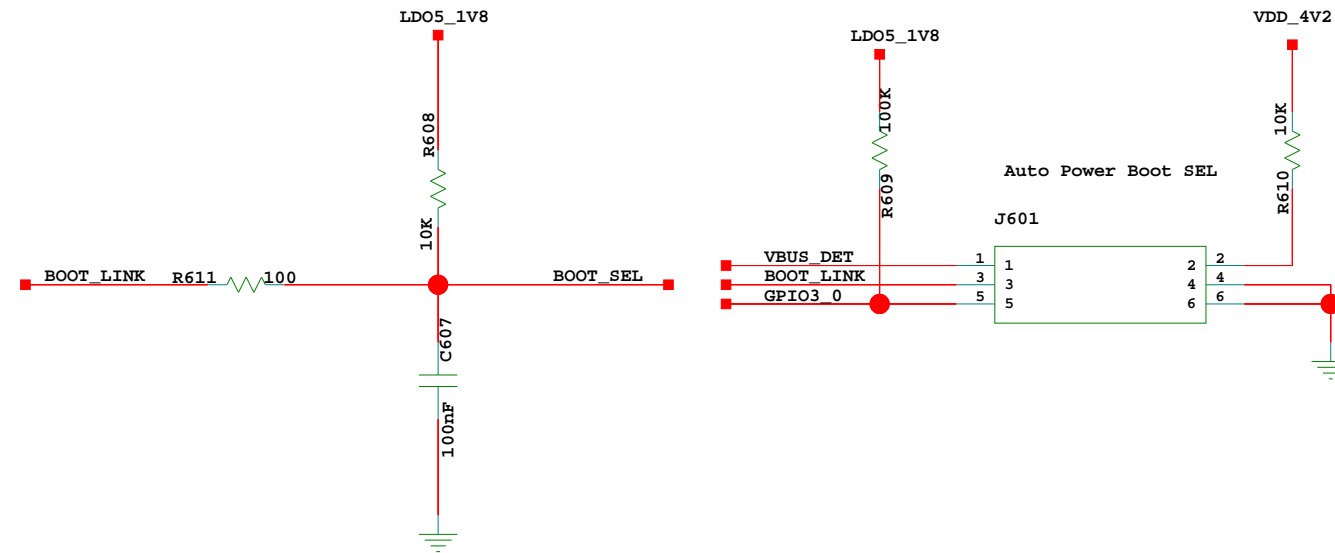
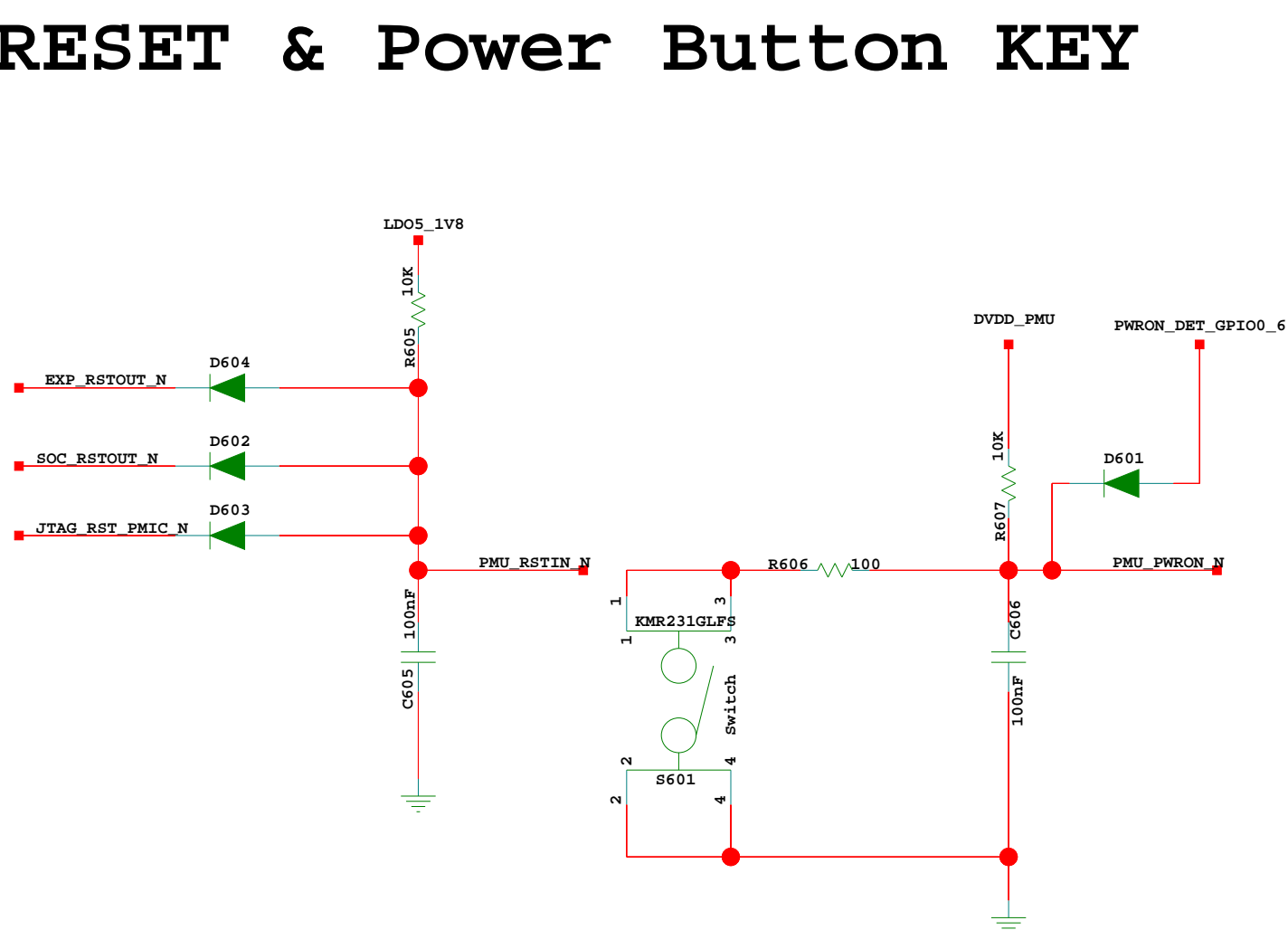

The type and specification of the components refer to the BOM

				ECA NO	DATE
DESIGNED					
REVIEWED					
		VER	PART_NUMBER	SHEET	OF
		A	Hi6220HiKEY		
				HUAWEI TECH CO.,LTD.	

PMU-Codec

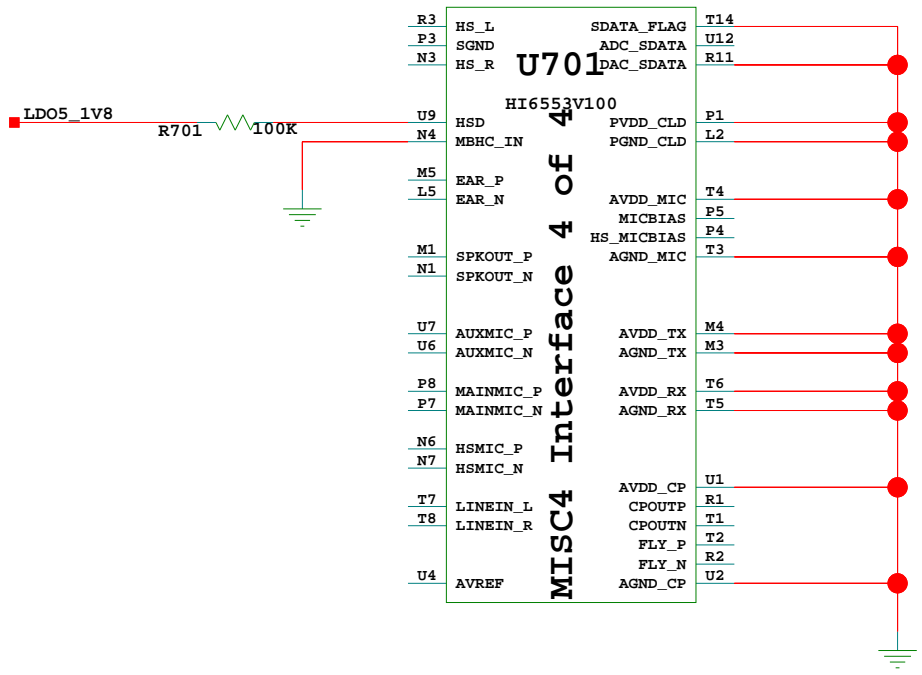

The type and specification of the components refer to the BOM

				ECA NO	DATE
DESIGNED					
REVIEWED					
		VER	PART_NUMBER	SHEET	OF
		A	Hi6220HiKEY	HUAWEI TECH CO.,LTD.	

SOC System IF

LDO5_1V8

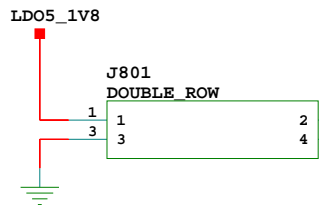
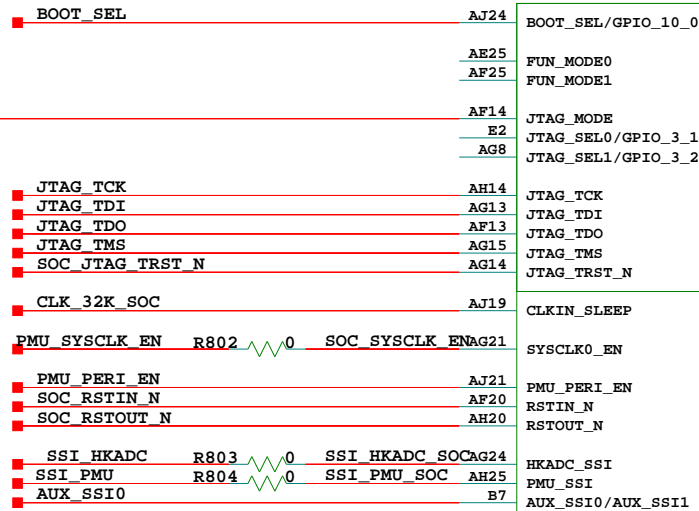

U1101

HI6220V100

MISC1 Interface 1 of 7

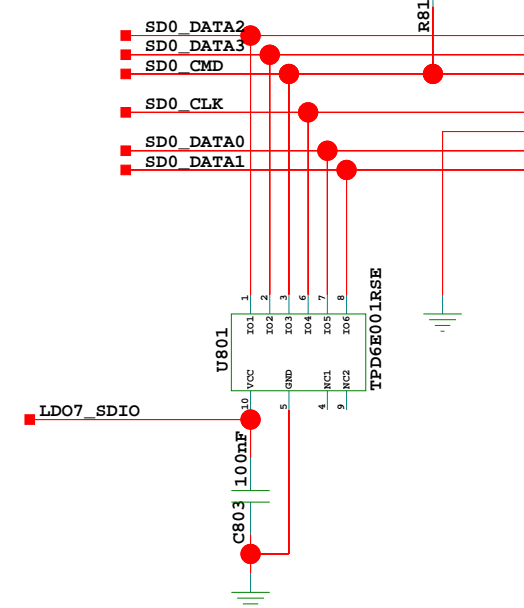
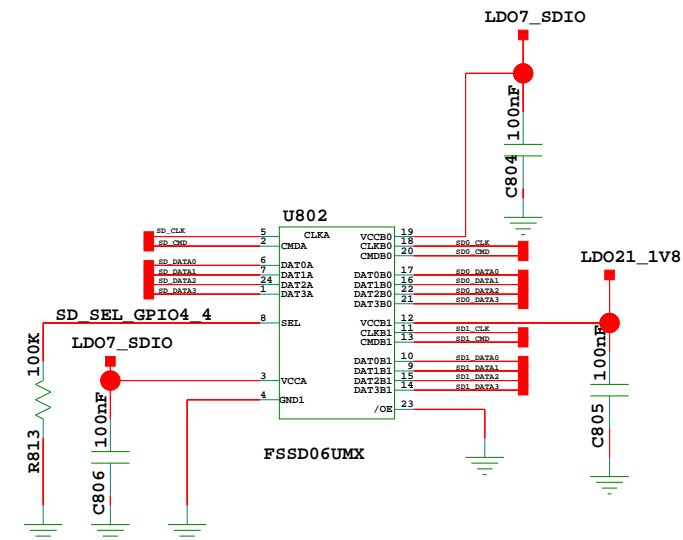
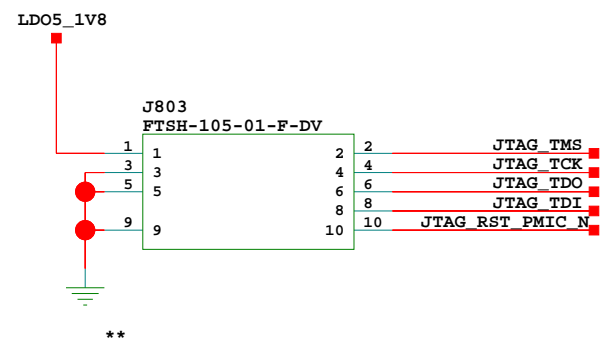
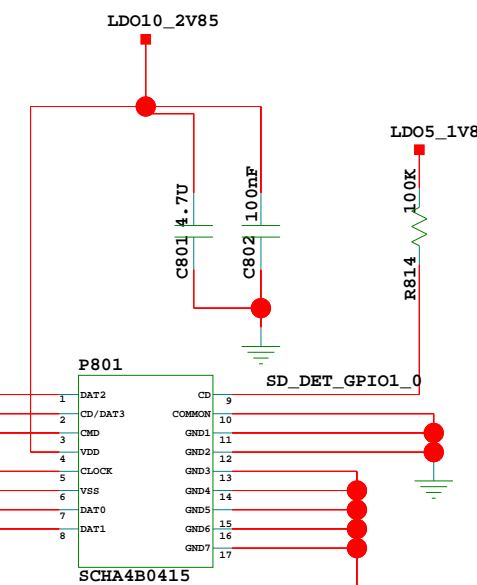
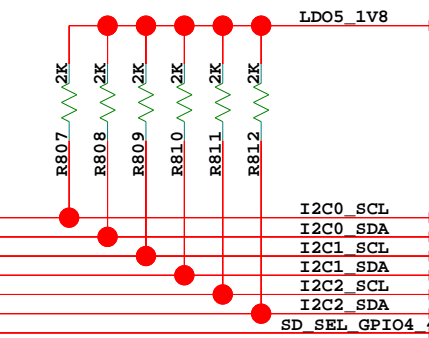
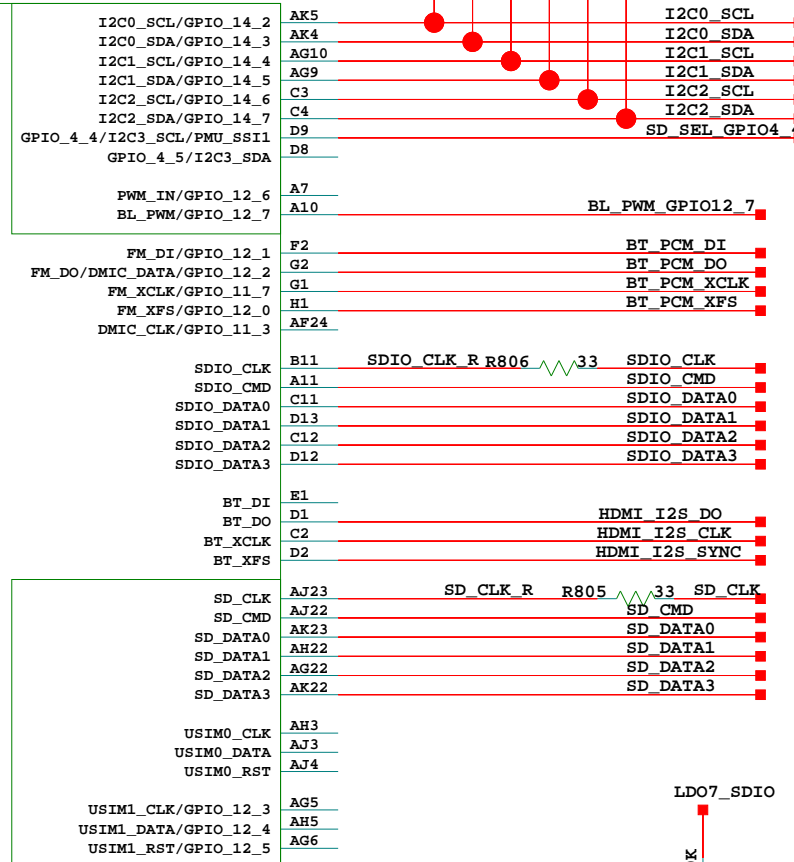

The type and specification of the components refer to the BOM

DESIGNED				ECA NO	DATE
REVIEWED					
	VER	PART_NUMBER	SHEET	OF	
		Hi6220HiKEY		HUAWEI TECH CO.,LTD.	

SOC Media IF

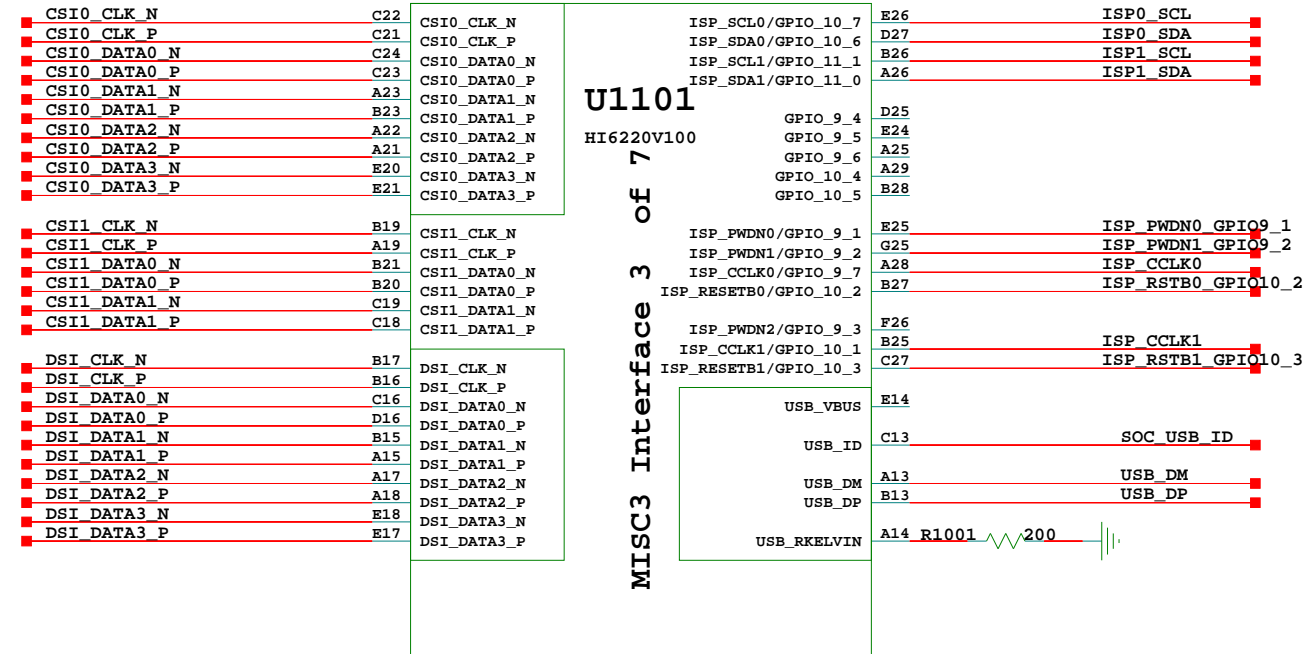

The type and specification of the components refer to the BOM

				ECA NO	DATE
DESIGNED					
REVIEWED					
		VER	PART_NUMBER	SHEET	OF
			Hi6220HIKEY	HUAWEI TECH CO.,LTD.	

SOC Memory IF

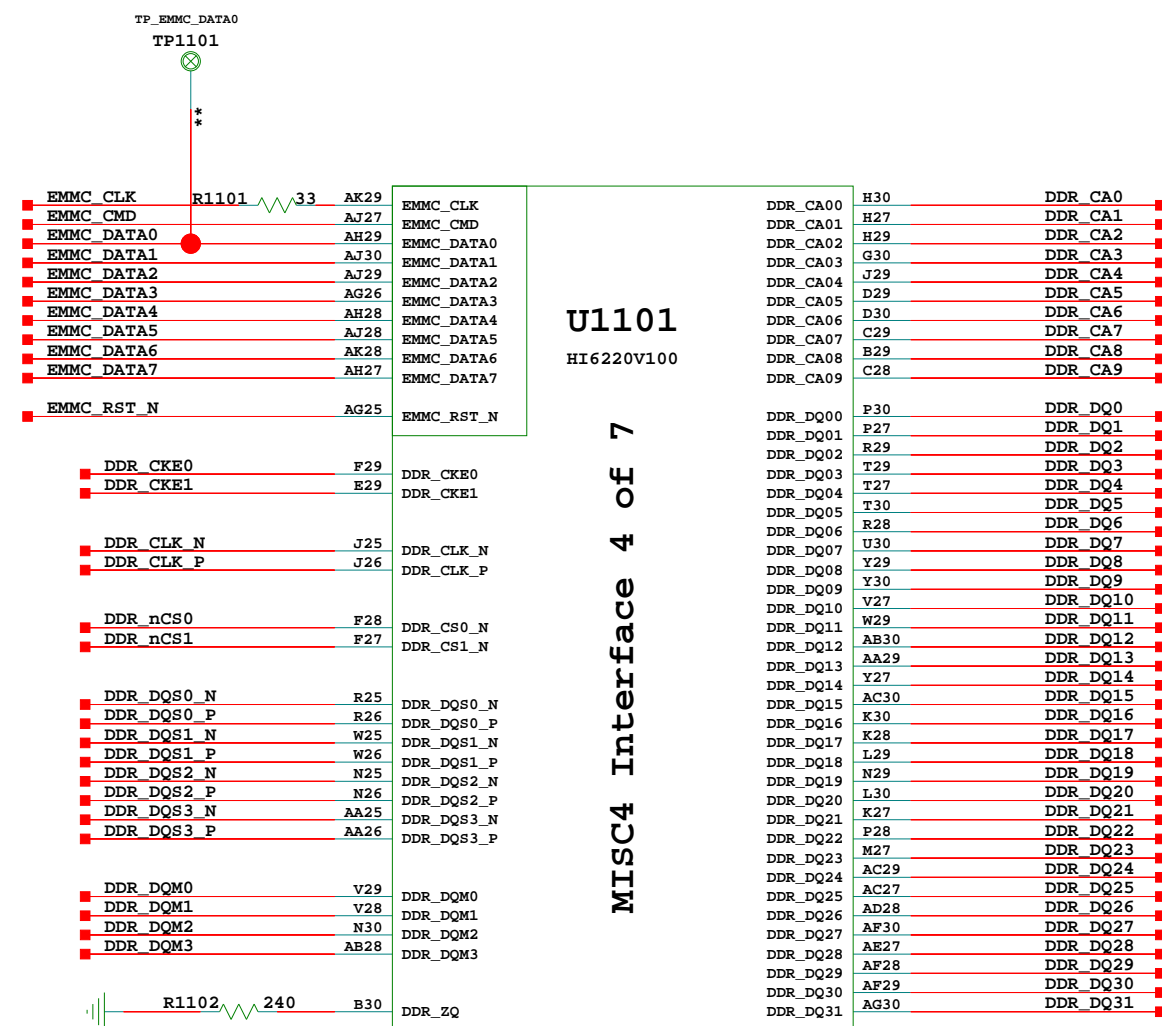

The type and specification of the components refer to the BOM

				ECA NO	DATE
DESIGNED					
REVIEWED					
		VER	PART_NUMBER	SHEET	OF
			Hi6220HIKEY	HUAWEI TECH CO.,LTD.	

SOC RF IF

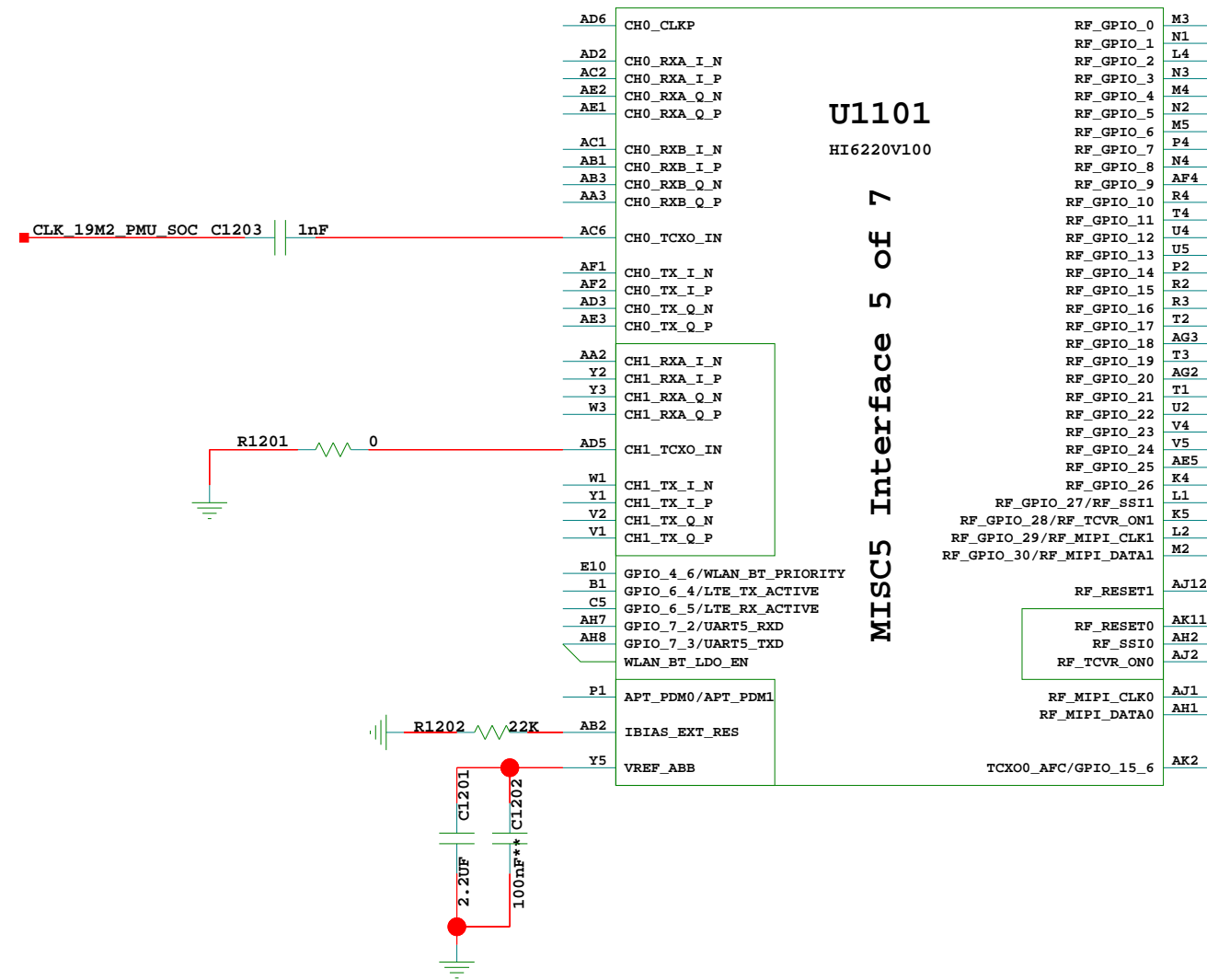

U1101
HI6220V100

MISC5 Interface 5 of 7

The type and specification of the components refer to the BOM

				ECA NO	DATE
DESIGNED					
REVIEWED					
		VER	PART_NUMBER	SHEET	OF
			Hi6220HIKEY	HUAWEI TECH CO.,LTD.	

SOC GND

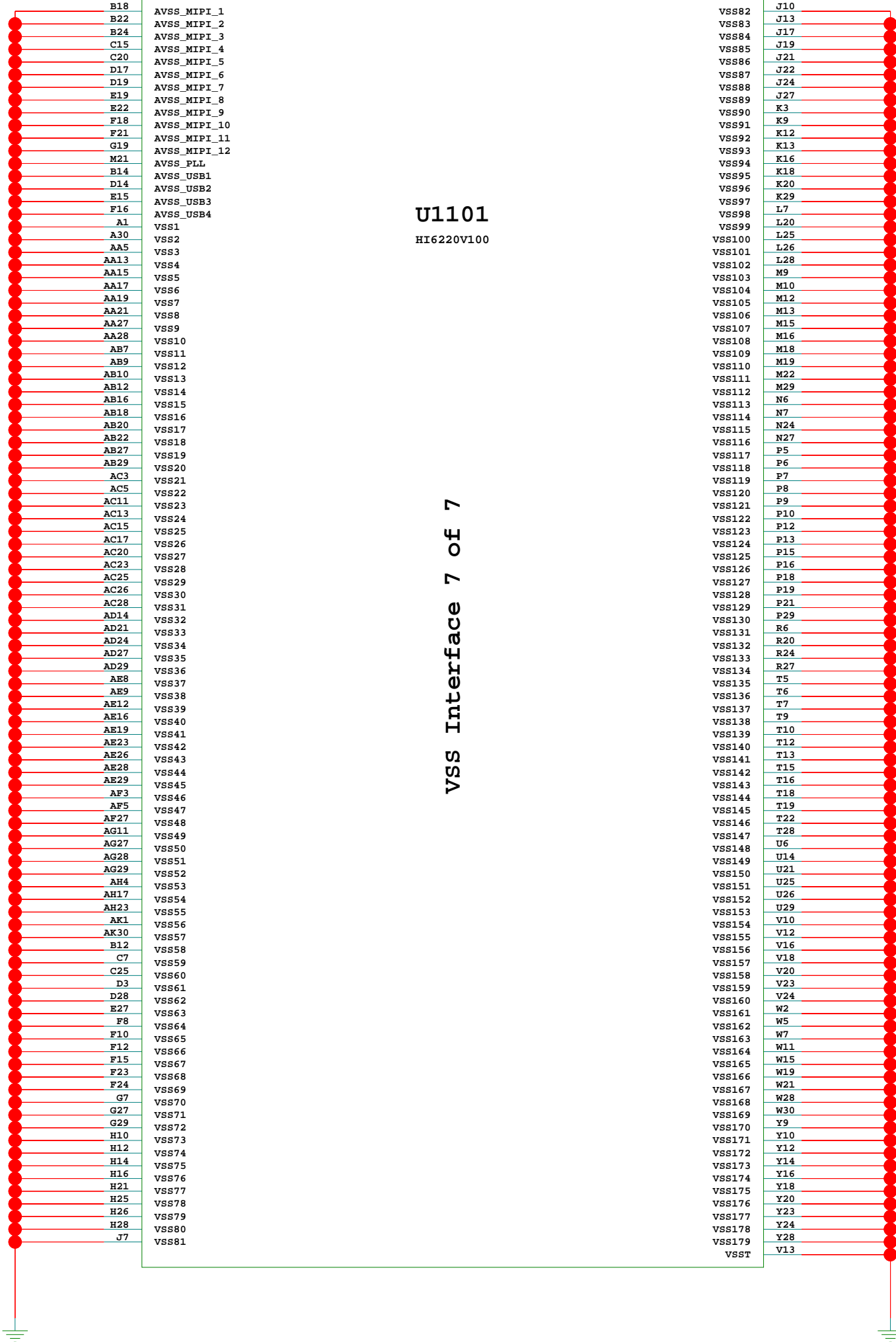

VSS Interface 7 of 7

The type and specification of the components refer to the BOM

				ECA NO	DATE
DESIGNED					
REVIEWED					
		VER	PART_NUMBER	SHEET	OF
			Hi6220HIKEY		
				HUAWAI TECH CO.,LTD.	

eMMC

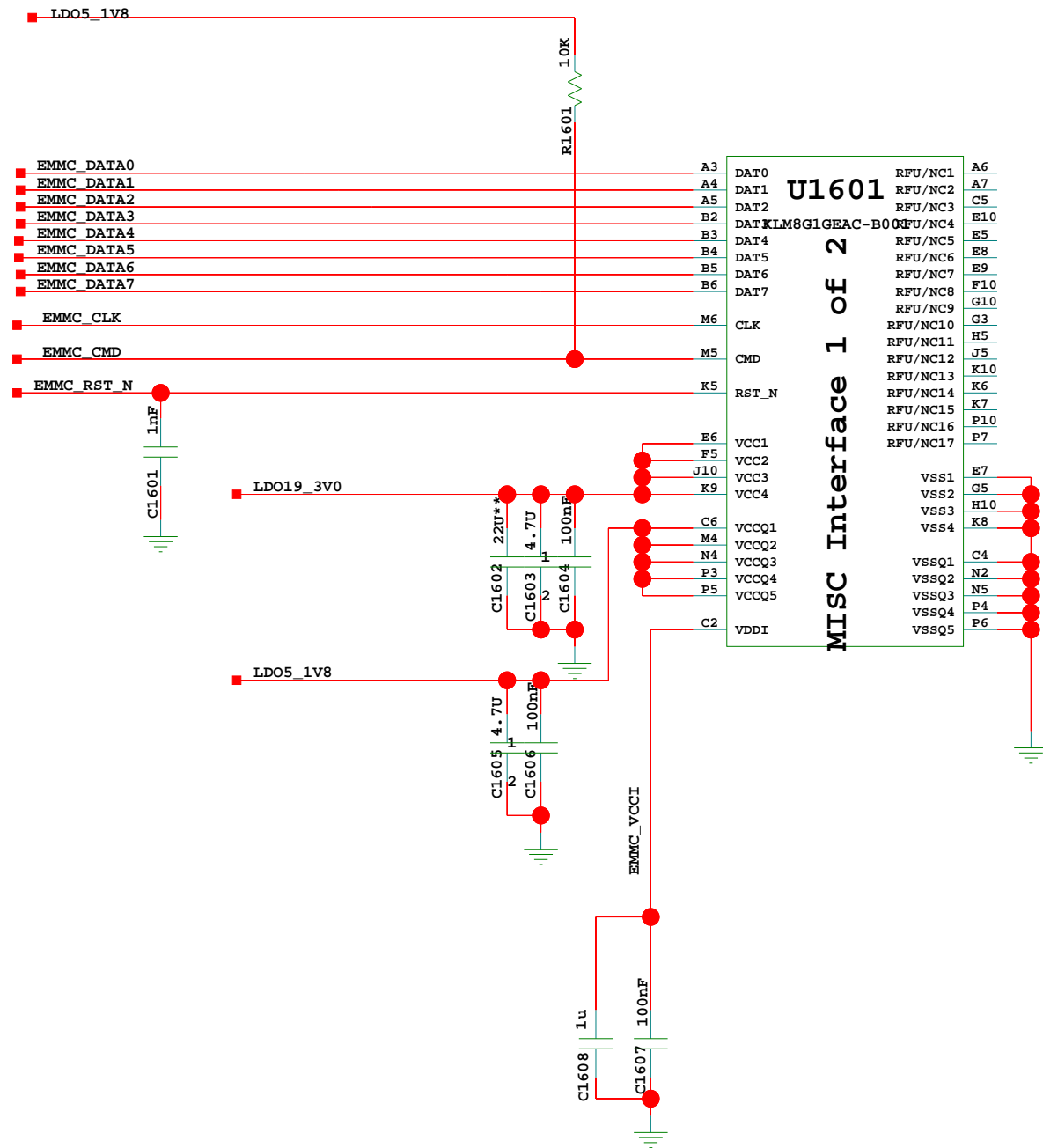

MISC Interface 1 of 2

U1601		KLM8G1GEAC-B001	
A1	NC1	NC54	H12
A10	NC2	NC55	H13
A11	NC3	NC56	H14
A12	NC4	NC57	H2
A13	NC5	NC58	H3
A14	NC6	NC59	J1
A2	NC7	NC60	J12
A8	NC8	NC61	J13
A9	NC9	NC62	J14
B1	NC10	NC63	J2
B10	NC11	NC64	J3
B11	NC12	NC65	K1
B12	NC13	NC66	K12
B13	NC14	NC67	K13
B14	NC15	NC68	K14
B7	NC16	NC69	K2
B8	NC17	NC70	K3
B9	NC18	NC71	L1
C1	NC19	NC72	L12
C10	NC20	NC73	L13
C11	NC21	NC74	L14
C12	NC22	NC75	L2
C13	NC23	NC76	L3
C14	NC24	NC77	M1
C3	NC25	NC78	M10
C7	NC26	NC79	M11
C8	NC27	NC80	M12
C9	NC28	NC81	M13
D1	NC29	NC82	M14
D12	NC30	NC83	M2
D13	NC31	NC84	M3
D14	NC32	NC85	M7
D2	NC33	NC86	M8
D3	NC34	NC87	M9
D4	NC35	NC88	N1
E1	NC36	NC89	N10
E12	NC37	NC90	N11
E13	NC38	NC91	N12
E14	NC39	NC92	N13
E2	NC40	NC93	N14
E3	NC41	NC94	N3
F1	NC42	NC95	N6
F12	NC43	NC96	N7
F13	NC44	NC97	N8
F14	NC45	NC98	N9
F2	NC46	NC99	P1
F3	NC47	NC100	P11
G1	NC48	NC101	P12
G12	NC49	NC102	P13
G13	NC50	NC103	P14
G14	NC51	NC104	P2
G2	NC52	NC105	P8
H1	NC53	NC106	P9

MISC Interface of

The type and specification of the components refer to the BOM

DESIGNED				ECA NO	DATE
REVIEWED					
		VER	PART_NUMBER	SHEET	OF
			Hi6220HIKEY		HUAWEI TECH CO.,LTD.

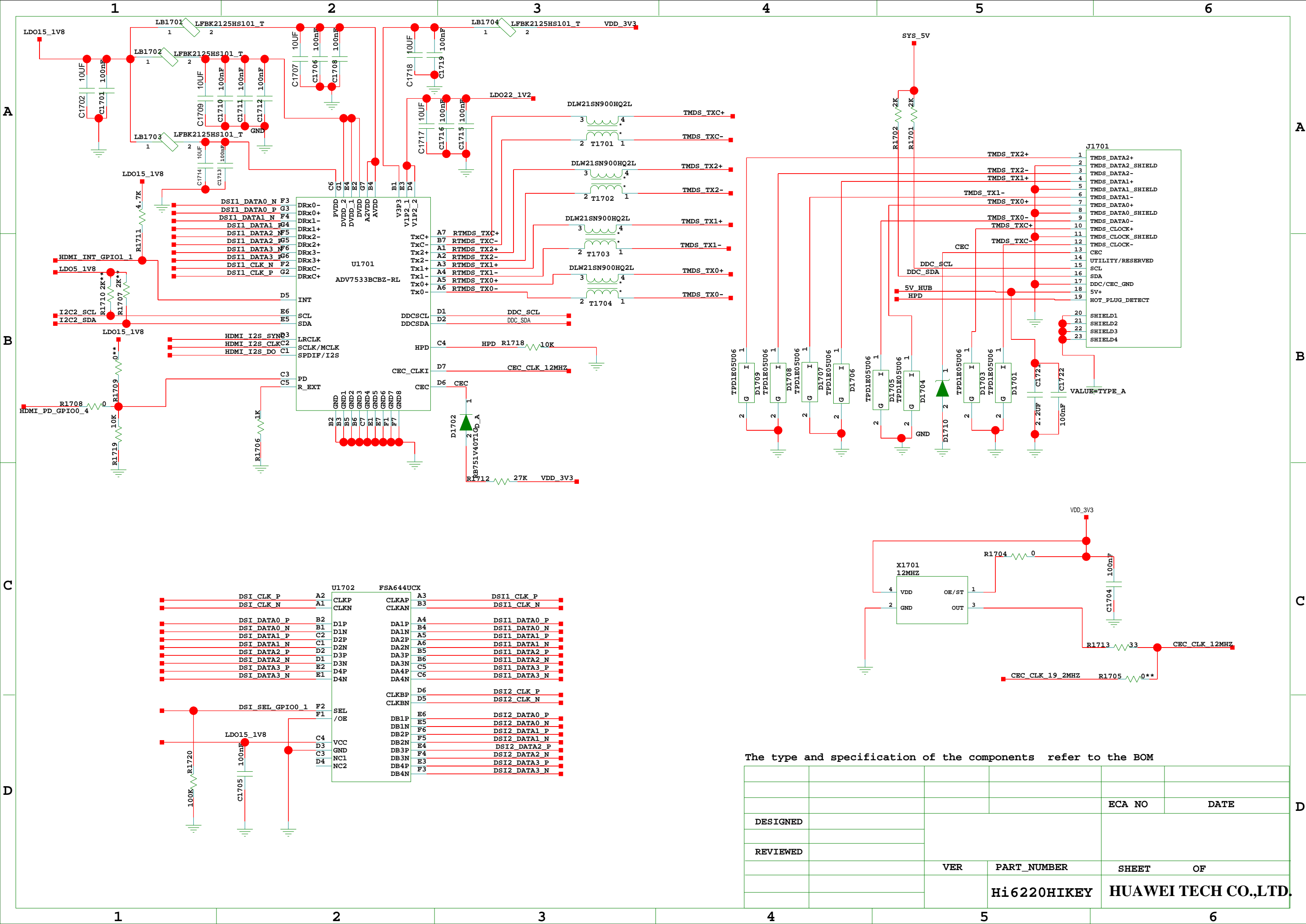

The type and specification of the components refer to the BOM

DESIGNED				ECA NO	DATE
REVIEWED					
	VER	PART_NUMBER	SHEET	OF	
		Hi6220HIKEY		HUAWEI TECH CO.,LTD.	

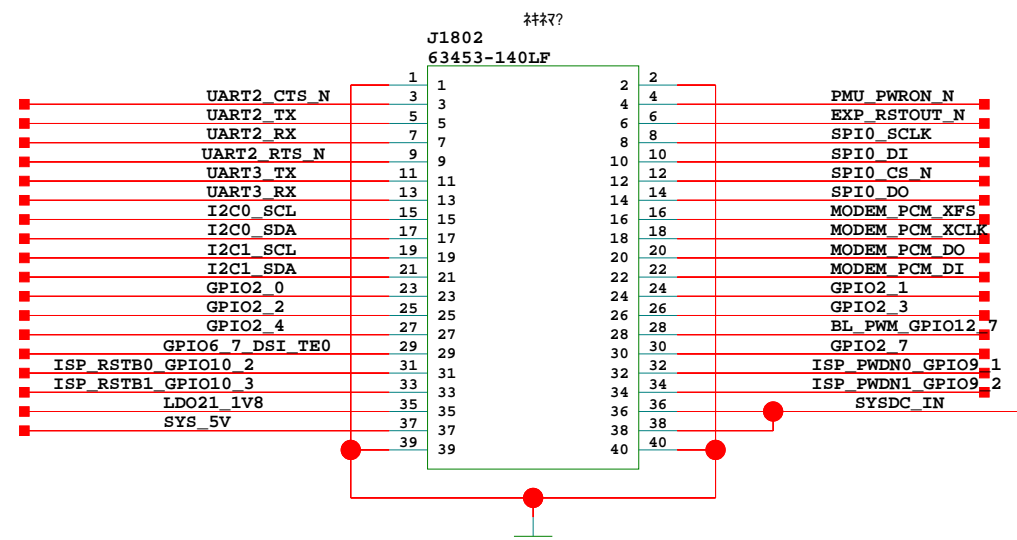
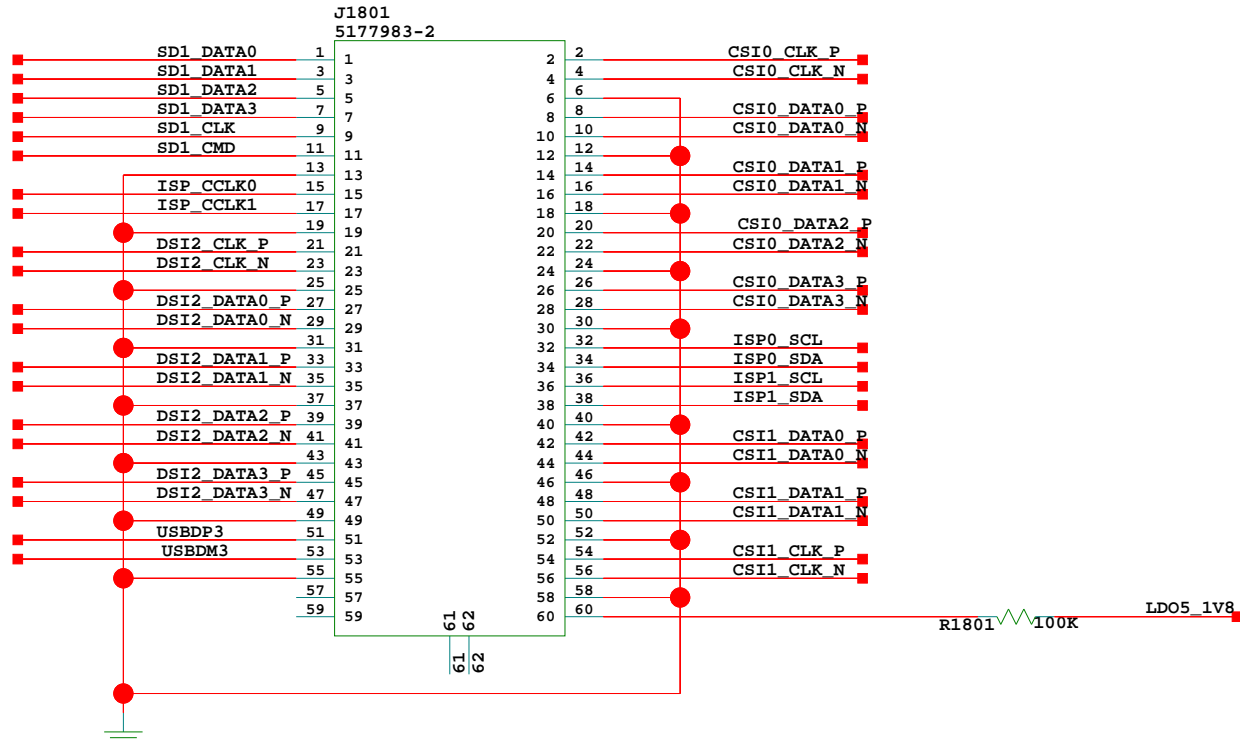
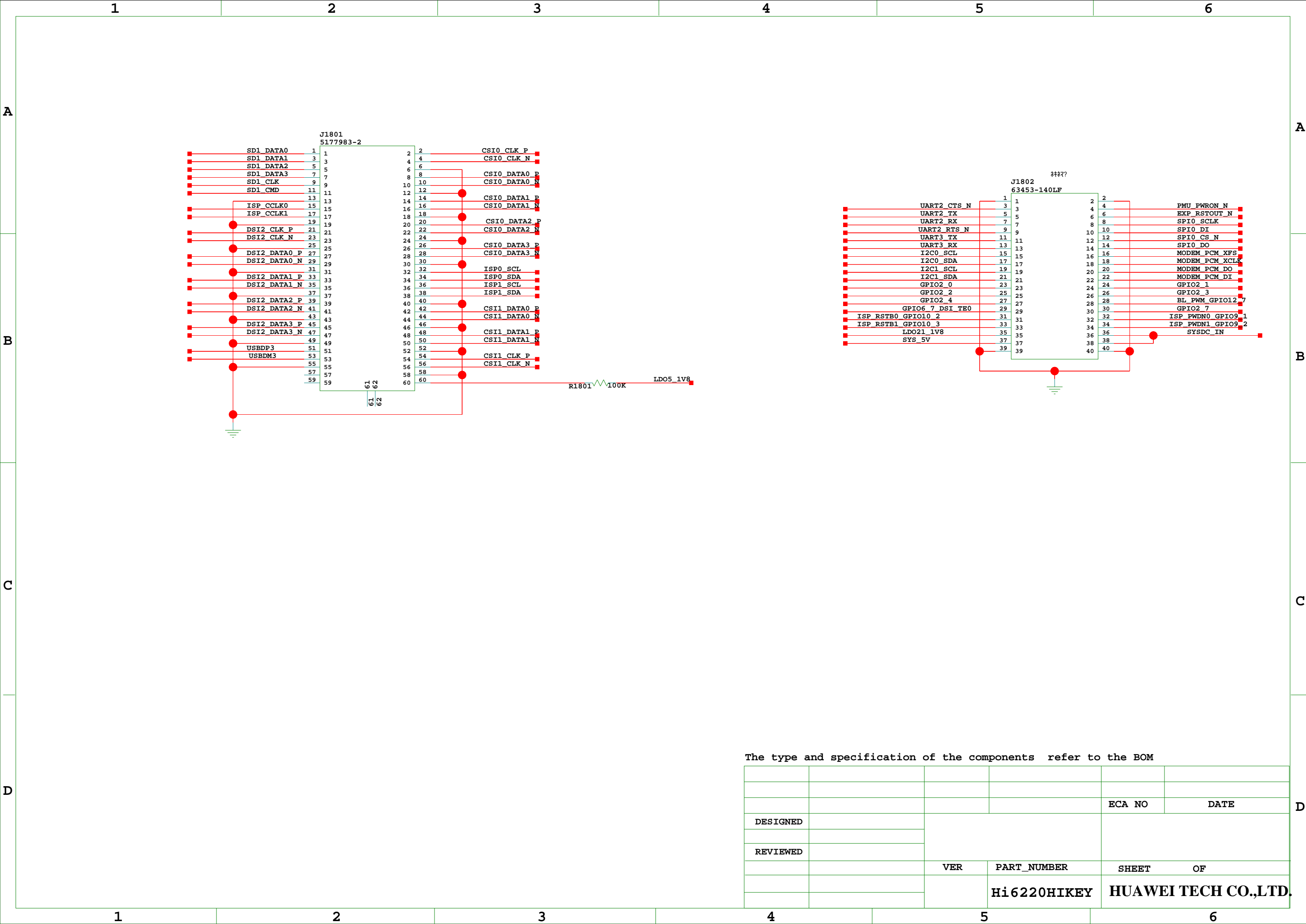

The type and specification of the components refer to the BOM

				ECA NO	DATE
DESIGNED					
REVIEWED					
		VER	PART_NUMBER	SHEET	OF
			Hi6220HIKEY		
				HUAWAI TECH CO.,LTD.	

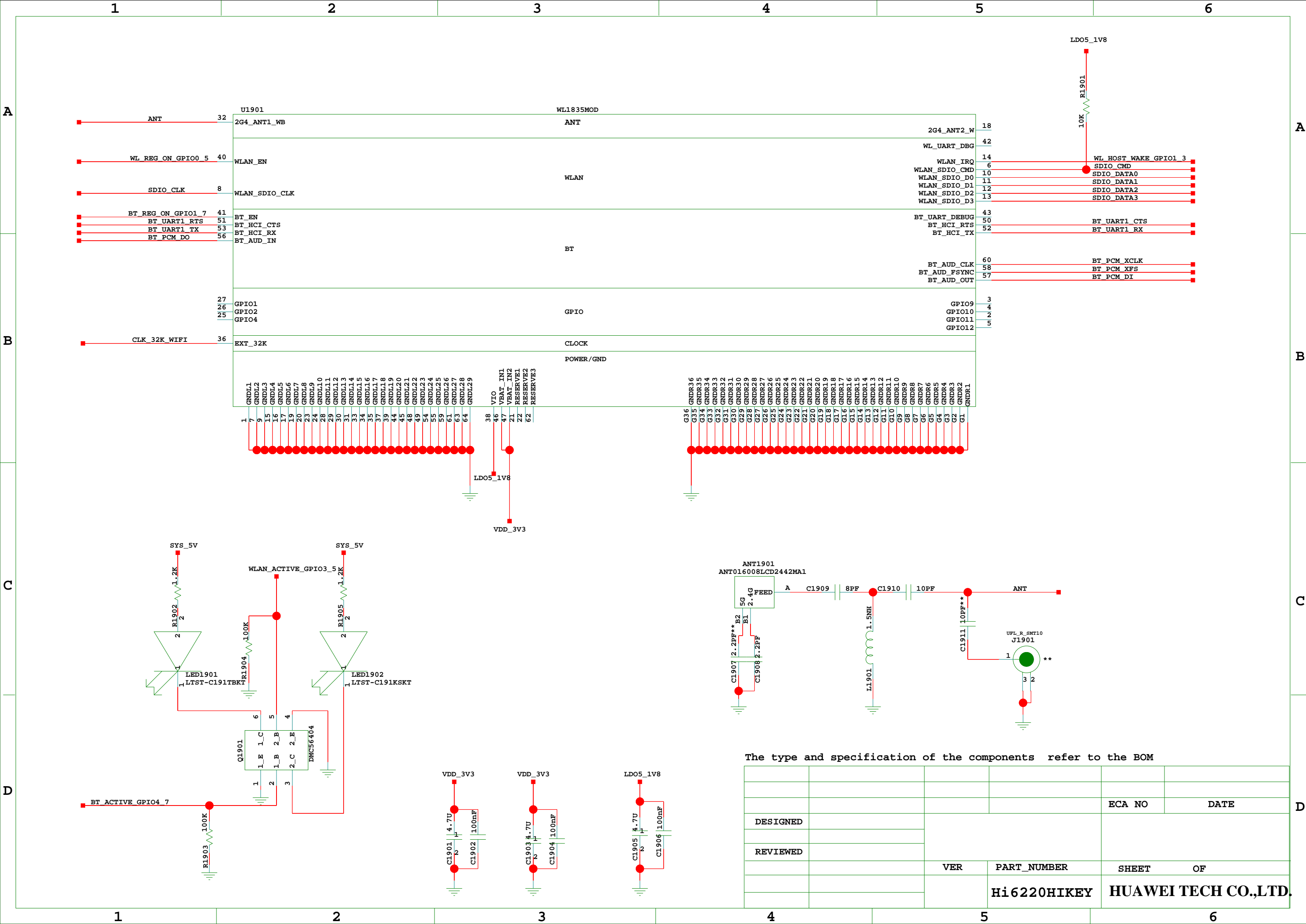

The type and specification of the components refer to the BOM

		ECA NO	DATE
DESIGNED			
REVIEWED			
VER	PART_NUMBER	SHEET	OF
	Hi6220HIKEY		
		HUAWEI TECH CO.,LTD.	